

Determining the Molar Volume of a Gas

Introduction

From blimps to airbags, gases are used to fill a wide variety of containers. How much of a particular gas must be produced to fill a container? The amount of gas needed to fill any size container can be calculated if the molar volume of the gas is known.

Concepts

- Avogadro's law
- Dalton's law
- Ideal gas law
- Molar volume

Background

Avogadro's law states that equal volumes of gases contain an equal number of molecules under the same conditions of temperature and pressure. It follows, therefore, that all gas samples containing the same number of molecules will occupy the same volume if the temperature and pressure are kept constant. The volume occupied by one mole of a gas is called the *molar volume*. In this experiment the molar volume of hydrogen gas at standard temperature and pressure (STP, equal to 273 K and 1 atm) will be measured.

The reaction of magnesium metal with hydrochloric acid (Equation 1) provides a convenient means of generating hydrogen in the lab.

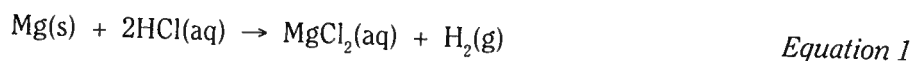

If the reaction is carried out with excess hydrochloric acid, the volume of hydrogen gas obtained will depend on the number of moles of magnesium as well as the pressure and temperature. The molar volume of hydrogen can be calculated if the volume occupied by a sample containing a known number of moles of hydrogen is measured. Since the volume will be measured under laboratory conditions of temperature and pressure, the measured volume must be corrected to STP conditions before calculating the molar volume.

The relationship among the four gas variables—pressure (P), volume (V), temperature (T), and the number of moles (n)—is expressed in the ideal gas law (Equation 2), where R is a constant called the universal gas constant.

$$PV = nRT \quad \text{Equation 2}$$

The ideal gas law reduces to Equation 3, the combined gas law, if the number of moles of gas is constant. The combined gas law can be used to calculate the volume (V_2) of a gas at STP (T_2 and P_2) from the volume (V_1) measured under any other set of laboratory conditions (T_1 and P_1). In using either the ideal gas law or the combined gas law, remember that temperature must always be expressed in units of kelvins (K) on the absolute temperature scale.

$$\frac{P_1V_1}{T_1} = \frac{P_2V_2}{T_2} \quad \text{Equation 3}$$

Hydrogen gas will be collected by the displacement of water in an inverted gas measuring tube (also called a eudiometer tube) using the apparatus shown in Figure 1. The total pressure of the gas in the tube will be equal to the barometric (air) pressure. However, the gas in the cylinder will not be pure hydrogen. The gas will also contain water vapor due to the evaporation of the water molecules over which the hydrogen is being collected. According to Dalton's law, the total pressure of the gas will be equal to the partial pressure of hydrogen plus the partial pressure of water vapor (Equation 4). The vapor pressure of water depends only on the temperature (see Table 1).

$$P_{\text{total}} = P_{\text{H}_2} + P_{\text{H}_2\text{O}} \quad \text{Equation 4}$$

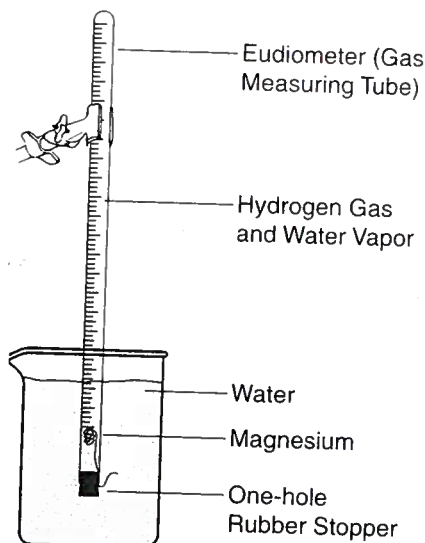

Figure 1.

Table 1. Vapor Pressure of Water at Different Temperatures

Temperature, °C	$P_{\text{H}_2\text{O}}$, mm Hg	Temperature, °C	$P_{\text{H}_2\text{O}}$, mm Hg
16	13.6	22	19.8
17	14.5	23	21.1
18	15.5	24	22.4
19	16.5	25	23.8
20	17.5	26	25.2
21	18.7	27	26.7

Experiment Overview

The purpose of this experiment is to determine the volume of one mole of hydrogen gas at standard temperature and pressure (STP). Hydrogen will be generated by the reaction of a known mass of magnesium with excess hydrochloric acid in an inverted gas measuring tube filled with water. The volume of hydrogen collected by water displacement will be measured and corrected for differences in temperature and pressure in order to calculate the molar volume of hydrogen at STP.

Pre-Lab Questions *(Use a separate sheet of paper to answer the following questions.)*

A reaction of 0.028 g of magnesium with excess hydrochloric acid generated 31.0 mL of gas. The gas was collected by water displacement in a 22 °C water bath. The barometric pressure in the lab that day was 746 mm Hg.

1. Use Dalton's law and the vapor pressure of water at 22 °C (Table 1) to calculate the partial pressure of hydrogen gas in the gas collecting tube.
2. Use the combined gas law to calculate the "corrected" volume of hydrogen at STP. *Hint:* Watch your units for temperature and pressure!
3. What is the theoretical number of moles of hydrogen that can be produced from 0.028 g of Mg? *Hint:* Refer to Equation 1 for the balanced equation for the reaction.
4. Divide the corrected volume of hydrogen by the theoretical number of moles of hydrogen to calculate the molar volume (in L/mol) of hydrogen at STP.

Materials

Chemicals

Hydrochloric acid, HCl, 2 M, 30 mL

Magnesium ribbon, Mg, approximately 4.5-cm pieces, 2

Distilled or deionized water

Equipment

Barometer

Metric ruler

Beaker, 400-mL

One-hole rubber stopper (sized to fit eudiometer tube)

Copper wire, Cu, 18-gauge, 15-cm long

Scissors or wire cutter

Eudiometer tube, 50-mL

Thermometer

Graduated cylinder, 500-mL

Wash bottle

Graduated cylinder, 25-mL

Safety Precautions

Hydrochloric acid is a corrosive liquid. Avoid contact with eyes and skin and clean up all spills immediately. Magnesium metal is a flammable solid. Keep away from flames and other sources of ignition. Wear chemical splash goggles and chemical-resistant gloves and apron. Wash hands thoroughly with soap and water before leaving the laboratory.

Procedure

1. Fill a 400-mL beaker about $\frac{3}{4}$ -full with water.
2. Obtain or cut an approximately 4.5-cm piece of magnesium ribbon. Measure and record in the Data Table the exact length of the magnesium ribbon to the nearest 0.1 cm. Do not exceed 4.6 cm.
3. Your teacher will accurately measure the mass of 100-cm of magnesium metal to provide a conversion factor in g/cm to calculate the mass of magnesium used in this experiment. Multiply the length of magnesium ribbon by this conversion factor to calculate the mass of the piece of magnesium obtained in step 2. Record the mass of magnesium in the Data Table.
4. Obtain a piece of copper wire about 15-cm long. Twist and fold one end of the copper wire around a pencil to make a small "cage" into which the magnesium ribbon may be inserted. See Figure 2.
5. Firmly place the piece of magnesium into the copper wire cage. For larger pieces of magnesium, bend or fold the magnesium ribbon first.
6. Insert the straight end of the copper wire into a one-hole rubber stopper so that the cage end containing the magnesium is about 7 cm below the bottom of the stopper (see Figure 1). Hook the end of the copper wire around the top of the stopper to hold the cage in place.
7. Obtain about 15 mL of 2 M hydrochloric acid in a 25-mL graduated cylinder.
8. While holding the eudiometer tube in a tipped position, slowly add the 2 M hydrochloric acid to the tube.
9. While still holding the eudiometer tube in the tipped position, use a wash bottle to slowly and carefully fill the tube with water. Work slowly to avoid mixing the acid and the water layers. Fill the tube all the way to the top so no air remains in the tube.

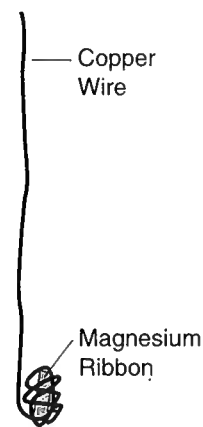

Figure 2.

10. Insert the magnesium–copper wire–stopper assembly into the eudiometer tube.
11. Place your finger over the hole of the rubber stopper, invert the eudiometer tube, and carefully lower the stoppered end of the tube into the 400-mL beaker containing water. The tube should contain no air bubbles. Clamp the tube in place (see Figure 3). The hydrochloric acid, being more dense than water, will diffuse downward through the tube and begin to react with the magnesium. The wire cage will keep the magnesium from floating up into the tube.
12. Record in the Data Table any evidence of a chemical reaction.
13. If the magnesium metal “escapes” its copper cage, gently shake the eudiometer tube up and down to work it back into the acidic solution. *Note:* Do not lift the tube completely out of the water in the beaker.
14. Allow the apparatus to stand for 5 minutes after the magnesium has completely reacted. Gently tap the sides of the eudiometer tube to dislodge any gas bubbles that may have become attached to the sides.
15. Fill a 500-mL graduated cylinder with tap water and place the cylinder in the sink.
16. Cover the hole in the stopper with your finger and transfer the eudiometer tube to the 500-mL graduated cylinder (see Figure 4).
17. Gently move the eudiometer tube up and down in the cylinder until the water level inside the tube is the same as the water level in the graduated cylinder. This is done to equalize the pressure with the surrounding air (barometric pressure). *Note:* Make sure the stoppered end of the eudiometer tube remains submerged in the water.
18. When the water levels inside and outside the tube are the same, measure and record in the Data Table the exact volume of hydrogen gas in the eudiometer tube.
19. Measure and record in the Data Table the temperature of the water bath in the 500-mL graduated cylinder. Using a barometer, measure and record the barometric pressure in the lab in the Data Table.
20. Remove the eudiometer tube from the graduated cylinder and discard the solution in the tube as directed by your instructor.
21. Repeat the entire procedure to obtain a second set of data. Record this as Trial 2 in the Data Table. If time permits, perform a third trial as well.

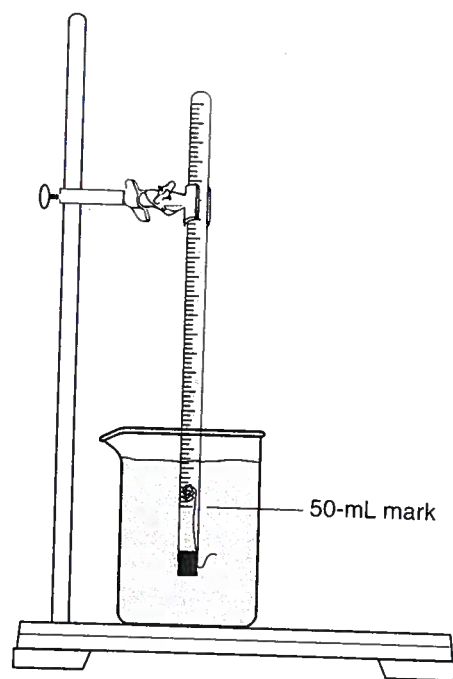

Figure 3.

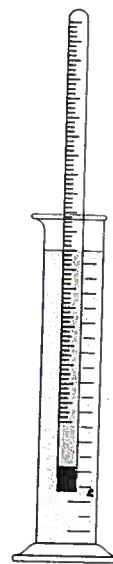

Figure 4.

Disposal and Cleanup

Your teacher will provide disposal and cleanup instructions.

Data Table

	Trial 1	Trial 2
Length of Mg Ribbon		
Mass of Mg		
Conversion Factor		
Evidence of Chemical Reaction		
Volume of H ₂ Gas		
Corrected Volume of H ₂ AT STP		
Barometric Pressure		

Post-Lab Calculations and Analysis

Construct a Results Table to summarize the results of the following calculations.

1. Calculate the theoretical number of moles of hydrogen gas produced in Trials 1 and 2.
2. Use Table 1 in the *Background* section to find the vapor pressure of water at the temperature of the water bath in this experiment. Calculate the partial pressure of hydrogen gas produced in Trials 1 and 2.
3. Use the combined gas law to convert the measured volume of hydrogen to the "ideal" volume the hydrogen gas would occupy at STP for Trials 1 and 2. *Hint:* Remember the units!
4. Divide the volume of hydrogen gas at STP by the theoretical number of moles of hydrogen to calculate the molar volume of hydrogen for Trials 1 and 2.

Experiment 8

5. What is the average value of the molar volume of hydrogen? Look up the literature value of the molar volume of a gas at STP in your textbook and calculate the percent error in your experimental determination of the molar volume of hydrogen.

$$\text{Percent error} = \frac{|\text{Experimental value} - \text{Literature value}|}{\text{Literature value}} \times 100\%$$

6. One mole of hydrogen gas has a mass of 2.02 g. Use your value of the molar volume of hydrogen to calculate the mass of one liter of hydrogen gas at STP. This is the density of hydrogen in g/L. How does this experimental value of the density compare with the literature value? (Consult a chemistry handbook for the density of hydrogen gas at STP.)
7. In setting up this experiment, a student noticed that a bubble of air leaked into the eudiometer tube when it was inverted in the water bath. What effect would this have on the measured volume of hydrogen gas? Would the calculated molar volume of hydrogen be too high or too low as a result of this error? Explain.
8. A student noticed that the magnesium ribbon appeared to be oxidized—the metal surface was black and dull rather than silver and shiny. What effect would this error have on the measured volume of hydrogen gas? Would the calculated molar volume of hydrogen be too high or too low as a result of this error? Explain.

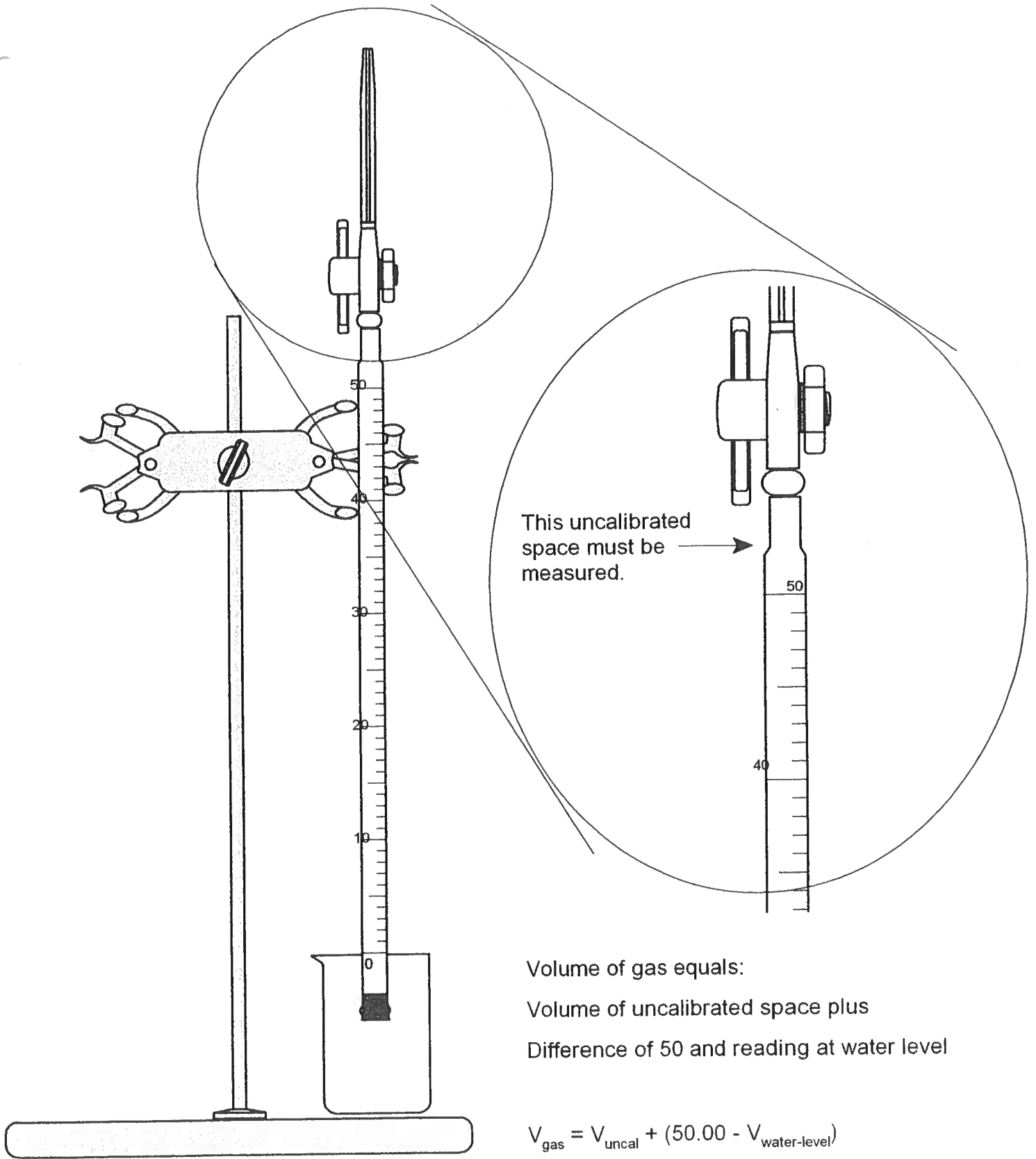

Volume of gas equals:
Volume of uncalibrated space plus
Difference of 50 and reading at water level

$$V_{\text{gas}} = V_{\text{uncal}} + (50.00 - V_{\text{water-level}})$$

- Instead of using the large graduated cylinder, an alternate method of finding the pressure of gases inside the gas measuring tube when the water levels inside and outside the tube are different is shown below.

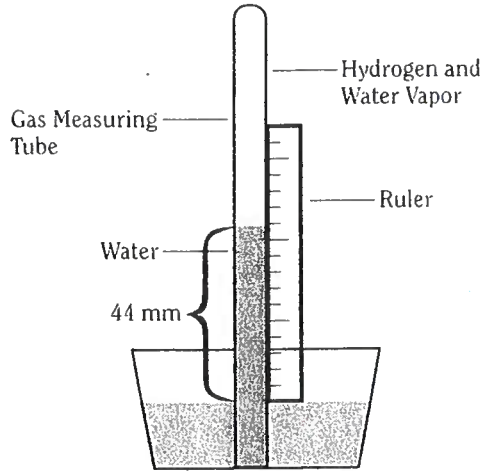

Measuring the Difference in Water Levels

Take a ruler and measuring in mm the difference in heights of the water levels, as shown above. This height, in mm H₂O, can be converted to mm Hg by using the conversion factor that the force exerted by 1.00 mm Hg is the same as that exerted by 13.6 mm H₂O. For example, if the difference in levels is 44 mm H₂O, the correction would be:

$$P_{\text{levels}} = 44 \text{ mm H}_2\text{O} \times \frac{1 \text{ mm Hg}}{13.6 \text{ mm H}_2\text{O}} = 3 \text{ mm Hg}$$

This correction should be subtracted from the atmospheric pressure to get the pressure of the gases inside the tube.

How to

- CALIBRATE UNMARKED VOL. IN BURET
- ① FILL BURET TO ABOUT 46 OR 47 mL, FILL TIP BY DRAINING INTO A BEAKER
 - ② WAIT FOR DRIPS ON INSIDE WALLS OF BURET, THEN READ TO ±0.01 mL (VOL MUST BE A LITTLE ABOVE 50 mL MARK)
 - ③ DRAIN OUT ALL WATER BUT ONLY UNTIL IT JUST TOUCHES THE TOP OF THE STOPCOCK (DRAIN INTO A 10-ML GRAD CYL)
 - ④ READ VOL IN 10-ML GRAD CYL TO ±0.01 mL
 - ⑤ FROM VOL. IN CYL SUBTRACT AMOUNT OF VOL. ABOVE 50 mL MARK OF BURET
 - ⑥ REPEAT UNTIL CONSISTENT (3X MINIMUM)

V_i BURET REMAINING BEFORE DRAINING

V_c VOL IN GRAD CYL

V_{UNCAL} VOL IN UNCALIBRATED SPACE OF BURET

$$V_{\text{UNCAL}} = V_c - (50 - V_i)$$